5. WAVE ENERGY, GROUP SPEED AND ENERGY FLUX

i. Group Speed

In this section, we shall discuss some very interesting properties of waves associated with wave energy. First, we shall define a kinematic quantity, known as the group speed, which governs some important properties associated with amplitude modulation, energy propagation, wave-number conservation etc. The group speed, denoted as C_g (in the text book as C_n , is defined as

$$C_g \equiv \frac{d\sigma}{dk} \quad (96)$$

where, as before, σ denotes the radian frequency and k the wave number. As $\sigma^2 = gk \text{TANH}kh$, we have

$$C_g \equiv \frac{d\sigma}{dk} = \frac{d}{dk} [gk \text{TANH}kh]^{1/2} \quad (97)$$

which can be shown to be

$$C_g = \frac{1}{2} \frac{\sigma}{k} \left[1 + \frac{2kh}{\text{SINH}2kh} \right] \quad (98)$$

or, as $C_p \equiv \sigma/k$,

$$C_g = \frac{1}{2} \frac{\sigma}{k} \left[1 + \frac{2kh}{\text{SINH}2kh} \right] = \frac{C_p}{2} \left[1 + \frac{2kh}{\text{SINH}2kh} \right] \quad (99)$$

In the case of deep-water/short waves (ie. $kh \geq \pi$), the ratio $2kh/\text{SINH}2kh \rightarrow 0$, and therefore

$$C_g = \frac{C_p}{2} \quad \text{for deep-water/short waves} \quad (100)$$

On the other hand, in the case of shallow-water/long waves (ie., $kh \leq \pi/10$), the ratio $2kh/\text{SINH}2kh \rightarrow 1$, and therefore

$$C_g = C_p = \sigma/k \quad \text{for shallow-water/long waves} \quad (101)$$

ii. Wave Energy

Next, let us obtain expressions for wave energy (potential and kinematic) using a long-crested progressive wave solution

$$\eta = \frac{H}{2} \sin(kx - \sigma t) \quad (102)$$

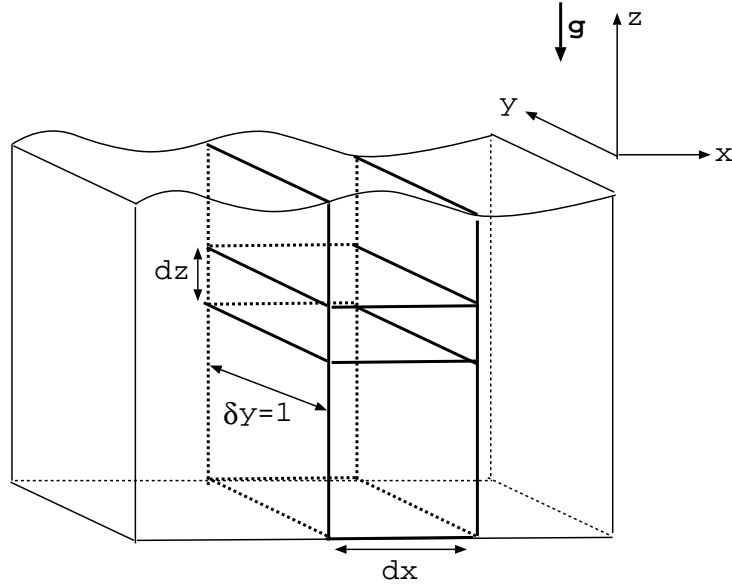

Fig 5-1. Wave energy in a column

$$\phi = \frac{H g}{2 \sigma} \frac{\text{COSH}k(h+z)}{\text{COSH}kh} \cos(kx - \sigma t) \quad (103)$$

Consider a column of water of width $\delta y = 1$ along y direction, dx along x direction, as shown in the figure.

The instantaneous potential energy in the water column is equal to

$$\int_{z=-h}^{z=\eta} \rho g z \, dz dx \delta y \quad (104)$$

where $\delta y = 1$. For a column of unit-section area (ie. dx is also equal to 1), the potential energy is given by

$$\int_{-h}^{\eta} \rho g z \, dz \quad (105)$$

which can be decomposed into two integrals

$$\int_{-h}^0 \rho g z \, dz + \int_0^{\eta} \rho g z \, dz \quad (106)$$

where the first integral represents the energy in quiescent (static) state and the second that associated with the wave. The instantaneous wave potential energy density (density implying in a column of unit section area) is therefore

$$PE = \int_0^{\eta} \rho g z \, dz \quad (107)$$

The time average (averaged over a period T) is then

$$PE = \frac{1}{T} \int_t^{t+T} dt \int_0^\eta \rho g z dz \quad (108)$$

which when computed

$$PE = \frac{1}{T} \int_t^{t+T} dt \rho g \left[\frac{z^2}{2} \right]_0^\eta \quad (109)$$

for $\eta = \frac{H}{2} \sin(kx - \sigma t)$ yields

$$PE = \frac{1}{T} \int_t^{t+T} dt \rho g \frac{1}{2} \eta^2 = \frac{1}{T} \int_t^{t+T} dt \rho g \frac{1}{2} \left[\frac{H}{2} \sin(kx - \sigma t) \right]^2 = \frac{1}{16} \rho g H^2 \quad (110)$$

Note that the above averaging can be done in space, along x direction over a wave length, which will also yield the same result:

$$PE = 1L \int_x^{x+L} dx \rho g \left[\frac{z^2}{2} \right]_0^\eta = 1L \int_x^{x+L} dx \rho g \frac{1}{2} \left[\frac{H}{2} \sin(kx - \sigma t) \right]^2 = \frac{1}{16} \rho g H^2 \quad (111)$$

Thus the average wave potential energy density (ie. time or space averaged wave potential energy in a water column of unit section area) is given by

$$PE = \frac{1}{16} \rho g H^2 \quad (112)$$

Note that the wave energy is *proportional to the square of the wave height*.

Similarly one can compute the average wave kinetic energy density as

$$KE = \frac{1}{T} \int_t^{t+T} dt \int_{-h}^\eta \frac{1}{2} \rho (u^2 + w^2) dz \quad (113)$$

or as

$$KE = \frac{1}{L} \int_x^{x+L} dx \int_{-h}^\eta \frac{1}{2} \rho (u^2 + w^2) dz \quad (114)$$

A progressive wave solution for u and w are

$$u = \frac{H}{2} \frac{gk}{\sigma} \frac{\text{COSH}k(h+z)}{\text{COSH}kh} \sin(kx - \sigma t) \quad (115)$$

$$w = -\frac{H}{2} \frac{gk}{\sigma} \frac{\text{SINH}k(h+z)}{\text{COSH}kh} \cos(kx - \sigma t) \quad (116)$$

Substituting the above expressions for u and w in the equation for the wave kinetic energy density, one can obtain

$$KE = \frac{1}{16} \rho g H^2 \quad (117)$$

which is the same as that for the average wave potential energy. The total (potential + kinematic) average wave energy density is therefore

$$E = PE + KE = \frac{1}{8} \rho g H^2 \quad (118)$$

Again note that the wave energy is proportional to the square of the wave height.

Amplitude Modulation and Propagation as a Group

Next let us consider generation of two waves of same height in a narrow band; ie, differing in wave number and frequency slightly. Specifically, let

$$\eta = \eta_1 + \eta_2 \quad (119)$$

where

$$\eta_1 = \frac{H}{2} \cos(k_1 x - \sigma_1 t) \quad (120)$$

$$\eta_2 = \frac{H}{2} \cos(k_2 x - \sigma_2 t) \quad (121)$$

The wavenumbers k_1 and k_2 and frequencies σ_1 and σ_2 are as follows:

$$k_1 = k - \frac{\delta k}{2}; \quad k_2 = k + \frac{\delta k}{2} \quad (122)$$

$$\sigma_1 = \sigma - \frac{\delta \sigma}{2}; \quad \sigma_2 = \sigma + \frac{\delta \sigma}{2} \quad (123)$$

where k and σ denote the “central” wavenumber and frequency of the narrow band and δk and $\delta \sigma$ are small. Note that δk and $\delta \sigma$ can be howeverly (is this a English word) be small, as the relation between k and σ (dispersion relation) is a *continuous* function.

Expanding the temrs for η_1 and η_2 using trigonometric identities and grouping terms we can show that the sum becomes

$$\eta = \eta_1 + \eta_2 = \left[H \cos \frac{1}{2}(\delta k \cdot x - \delta \sigma \cdot t) \right] \cos(kx - \sigma t) \quad (124)$$

which represents a progressive wave of wavenumber k and frequency σ propagating along the +x direction. The amplitude however gets modulated by the term

$$\cos \frac{1}{2}(\delta k \cdot x - \delta \sigma \cdot t) \quad (125)$$

The phase of the amplitude modulation θ_{am} is given by

$$\theta_{am} = (\delta k \cdot x - \delta \sigma \cdot t) \quad (126)$$

which implies that the modulation also propagates along the +x direction. The speed of propagation of the modulation can be obtained as

$$d\theta_{am} = 0 \rightarrow \delta k \cdot dx - \delta \sigma \cdot dt = 0 \rightarrow \frac{dx}{dt} = \frac{\delta \sigma}{\delta k} \quad (127)$$

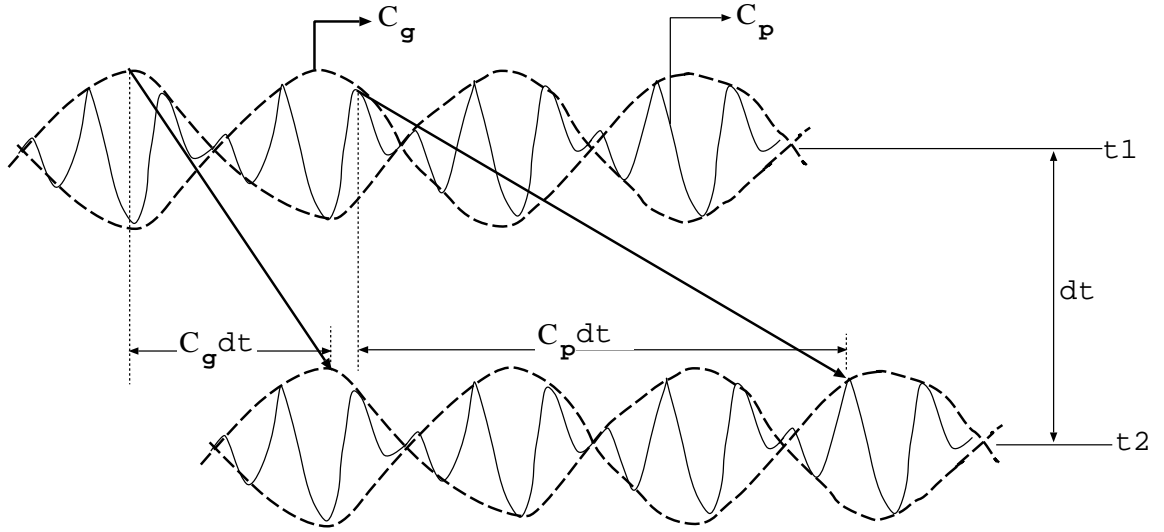

Fig 5-2. Amplitude Modulation of Gravity Waves

which in the limit $\delta k \rightarrow 0$ becomes equal to $\frac{d\sigma}{dk}$ which is nothing but the *group speed*!. In other words two waves generated in a narrow band, propagate with central wavenumber and central frequency and have the amplitude modulated with the amplitude modulation (ie. wave envelope) propagating at the group speed. This concept is illustrated in the figure above.

Flux of Wave Energy

Next, let us consider propagation of wave energy. For the derivation let us consider a progressive wave solution given by

$$\eta = \frac{H}{2} \sin(kx - \sigma t) \quad (128)$$

$$\phi = \frac{H g}{2 \sigma} \frac{\text{COSH}k(h+z)}{\text{COSH}kh} \cos(kx - \sigma t) \quad (129)$$

for which the dynamic pressure and the x component of fluid velocity are given by

$$p_{dyn} = \rho g \frac{H}{2} \frac{\text{COSH}k(h+z)}{\text{COSH}kh} \sin(kx - \sigma t) \quad (130)$$

$$u = \frac{H g k}{2 \sigma} \frac{\text{COSH}k(h+z)}{\text{COSH}kh} \sin(kx - \sigma t) \quad (131)$$

respectively.

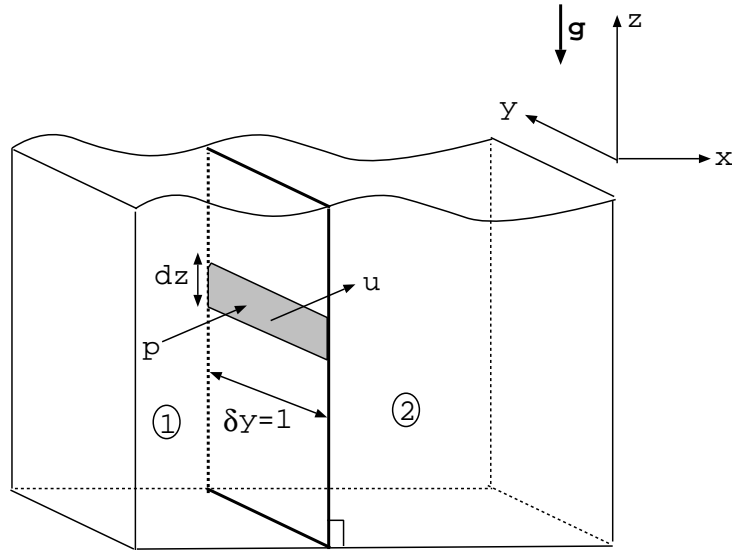

Fig 5-3. Flux of Wave energy

Consider a long-crested (no variation along y) wave propagating along the $+x$ direction as shown in Figure 5-3. Let a vertical control surface of unit width separate the fluid into two regions, fluid 1 on the left and fluid 2 on the right. Per first law of thermodynamics, the amount of energy crossing the control surface from left to right per unit time (flux of energy) is equal to the rate at which work is done by fluid 1 on fluid 2; ie.,

$$\mathcal{F} = \dot{W} = \int_{-h}^{\eta} p_{dyn} u \, dz \quad (132)$$

Note that power is defined as $\vec{force} \cdot \vec{velocity}$, and in the case of vertical surface the above becomes integration of p_{dyn} and u which are both along $+x$ direction. The average flux of energy (averaged over a wave period) is therefore

$$\bar{\mathcal{F}} = \frac{1}{T} \int_t^{t+T} dt \int_{-h}^{\eta} p_{dyn} u \, dz \quad (133)$$

Substituting the expressions for p_{dyn} and u given on the previous page corresponding to a progressive wave, we can show that

$$\bar{\mathcal{F}} = \left[\frac{1}{8} \rho g H^2 \right] \left[\frac{1}{2} \frac{\sigma}{k} \left(1 + \frac{2kh}{\text{SINH}2kh} \right) \right] = \bar{E} \cdot C_g \quad (134)$$

which proves that the *wave energy propagates at the group speed!*. The expression $\bar{\mathcal{F}} = \bar{E} \cdot C_g$ represents the average amount of wave energy propagating across a control surface of *unit crest width* per unit time. (Question: What is the average rate at which fluid mass is transported along the direction of wave propagation, in the case of small amplitude waves?!)